

5" DIAL ADJUST-ANGLE BIMETAL "E" SERIES - MODEL 5AAE

STANDARD FEATURES

- 5" dial size
- 2 1/2", 4" and 6" stems only
- All welded 304 stainless steel construction
- Silicone dampened bimetal element
- Sealed against dust, dirt and moisture
- Easy external recalibration adjustment
- Anti-parallax dial
- Accurate to 1% per ASME B40.3
- Over-range protection is 50% up to 500°F
- Fully gasketed glass lens

See page 20 for thermowells.

TEMPERATURE RANGES

CODE	FAHRENHEIT
02	-40/120°F
03	0/150°F
04	0/200°F
05	0/250°F
06	20/240°F
07	25/125°F
09	50/300°F
10	50/400°F
11	50/500°F

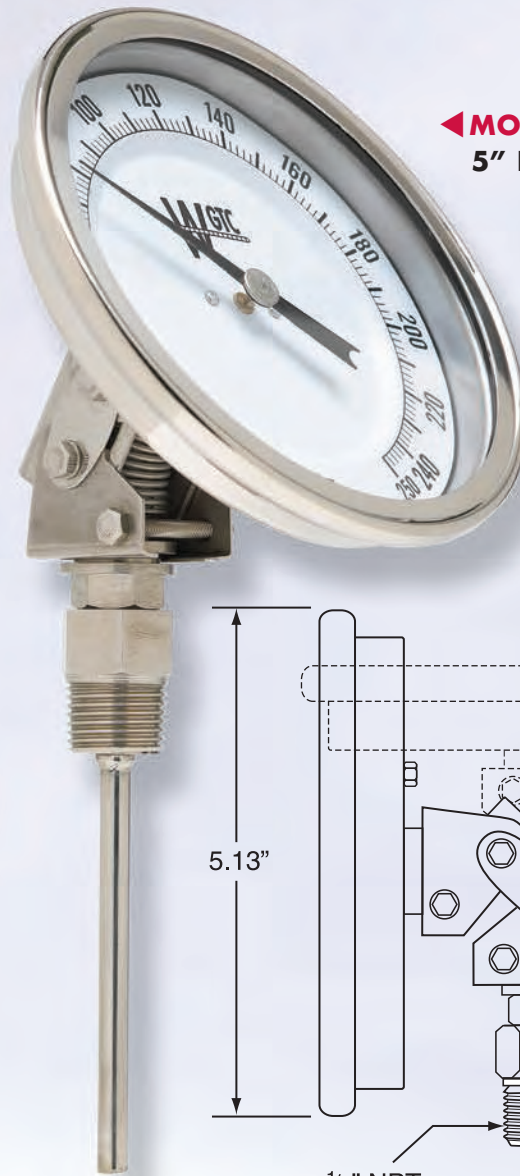

◀ **MODEL 5AAE**
5" Dial

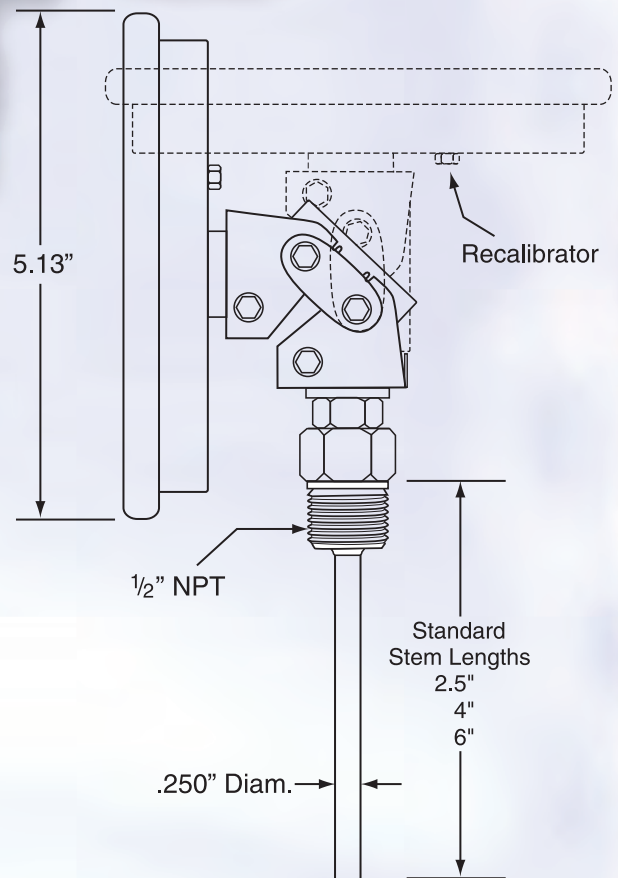

HOW TO ORDER - PLEASE SPECIFY THE FOLLOWING:

MODEL #	STEM LENGTH	"E" SERIES	RANGE
5AA	02 = 2 1/2" stem 06 = 6" stem 04 = 4" stem	E	2 digit code from table

Customer _____
 Project _____
 Engineer _____
 PRO or P.O. # _____

Weksler Glass Thermometer Corporation
 3295 Cobb International Blvd. • Kennesaw, GA 30152
 Telephone: 888-650-6923 • Fax: 770-429-0795 E-mail:
 Sales@WekslerGlass.com • Website: www.WekslerGlass.com