

# 3" DIAL BACK CONNECTED BIMETAL "E" SERIES - MODEL 3BKE

## STANDARD FEATURES

- 3" dial size
- 2 1/2", 4" and 6" stems only
- All welded 304 stainless steel construction
- Silicone dampened bimetal element
- Accurate to 1% per ASME B40.3
- External recalibration adjustment
- Anti-parallax dial
- Sealed to exclude dust, dirt, and moisture
- Over-range protection is 50% up to 500°F (10% above 500F)
- Fully gasketed glass lens

See page 20 for thermowells.



**MODEL 3BKE** ▶  
**3" Dial**

## TEMPERATURE RANGES

CODE	FAHRENHEIT
02	-40/120°F
03	0/150°F
04	0/200°F
05	0/250°F
06	20/240°F
07	25/125°F
09	50/300°F
10	50/400°F
11	50/500°F

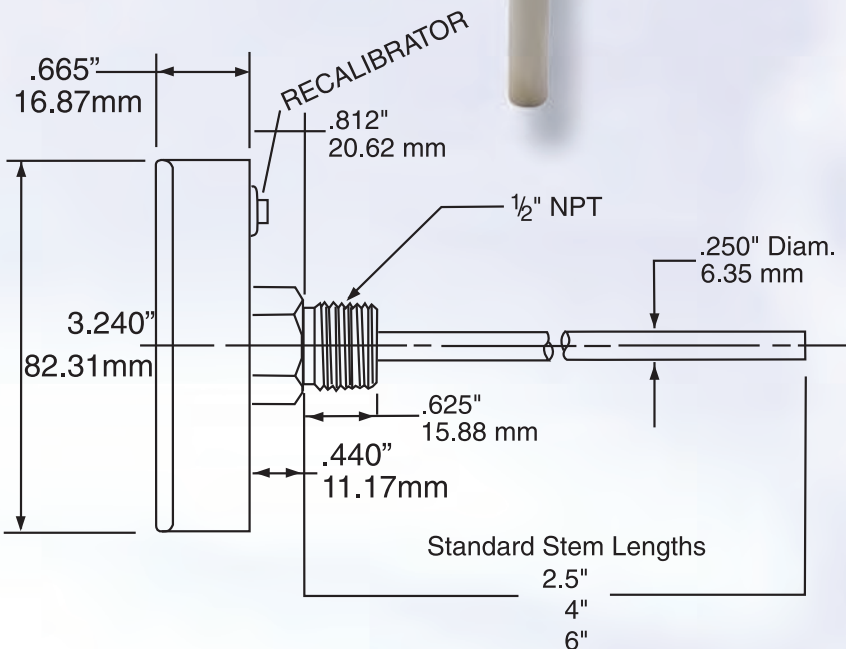

### HOW TO ORDER - PLEASE SPECIFY THE FOLLOWING:

MODEL #	STEM LENGTH	"E" SERIES	RANGE
<b>3BK</b>	<b>02</b> = 2 1/2" stem <b>06</b> = 6" stem <b>04</b> = 4" stem	<b>E</b>	<b>2 digit code</b> from table

Customer \_\_\_\_\_  
 Project \_\_\_\_\_  
 Engineer \_\_\_\_\_  
 PRO or P.O. # \_\_\_\_\_

Weksler Glass Thermometer Corporation  
 3295 Cobb International Blvd. • Kennesaw, GA 30152  
 Telephone: 888-650-6923 • Fax: 770-429-0795 E-mail:  
 Sales@WekslerGlass.com • Website: www.WekslerGlass.com