

# 5" DIAL BOTTOM CONNECTED BIMETAL MODEL 5BM

## STANDARD FEATURES

- 5" dial size
- All welded 304 stainless steel construction
- Silicone dampened bimetal element
- Easy external recalibration adjustment with 3/32" Allen Head wrench
- Anti-parallax dial
- Hermetically sealed per ASME B40.3
- Accurate to 1% per ASME B40.3 (for accurate reading thermometer must be immersed past groove on lower portion of stem)
- Over-range protection is 50% up to 500°F (10% above 500°F)
- Fully gasketed glass lens. Plastic or shatterproof lens is available.

See page 20 for thermowells.



## MODEL 5BM 5" Dial

3" dial available.  
See page 15.

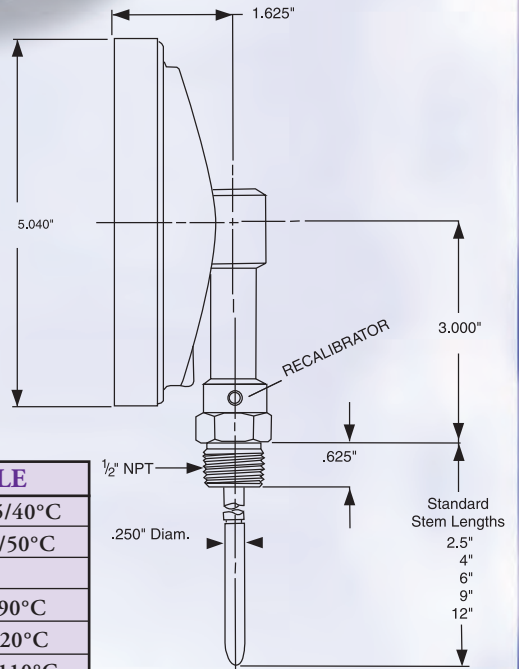

## TEMPERATURE RANGES

CODE	FAHRENHEIT	CODE	CELSIUS	CODE	DUAL SCALE
01	-100/100°F	CZ	-50/100°C	DB	-100/100°F & -75/40°C
02	-40/120°F	CB	-50/50°C	DE	-40/120°F & -40/50°C
03	0/150°F	CE	-50/25°C	-	-
04	0/200°F	CF	-40/70°C	DF	0/200°F & -10/90°C
05	0/250°F	CG	-10/110°C	DG	0/250°F & 20/120°C
06	20/240°F	CK	0/50°C	DK	20/240°F & -10/110°C
07	25/125°F	CN	0/100°C	DN	25/125°F & 0/50°C
08	50/250°F	CP	0/150°C	-	-
09	50/300°F	CQ	0/200°C	DQ	50/300°F & 10/150°C
10	50/400°F	CR	0/250°C	DR	50/400°F & 0/200°C
11	50/500°F	CS	0/300°C	DS	50/500°F & 0/250°C
12	150/750°F	CT	100/400°C	DT	150/750°F & 50/400°C
13	*200/1000°F	CU	*100/550°C	DU	*200/1000°F & 100/550°C

\*Not recommended for continuous use above 800°F or 425°C

- Silicone filled models available for extreme vibration or low temperature application

HOW TO ORDER - PLEASE SPECIFY THE FOLLOWING:			
MODEL #	STEM LENGTH	RANGE	OPTIONS
<b>5BM</b>	02 = 2 1/2" stem 04 = 4" stem 06 = 6" stem 09 = 9" stem 12 = 12" stem	2 digit code from tables	AA = Plastic Lens UU = Union Connection FF = Silicone Filled Case SS = Shatterproof Lens BB = 3/8" Diameter Stem

Customer \_\_\_\_\_  
 Project \_\_\_\_\_  
 Engineer \_\_\_\_\_  
 PRO or P.O. # \_\_\_\_\_

556 Dettor Rd., Suite 10, Charlottesville, VA 22903  
 Phone: 877.988.8003 | Fax: 866.982.9882  
 www.wekslerglass.com | sales@wekslerglass.com  
 International: Phone: 434.977.4544 | Fax: 434.977.4548